

**M-ONE**

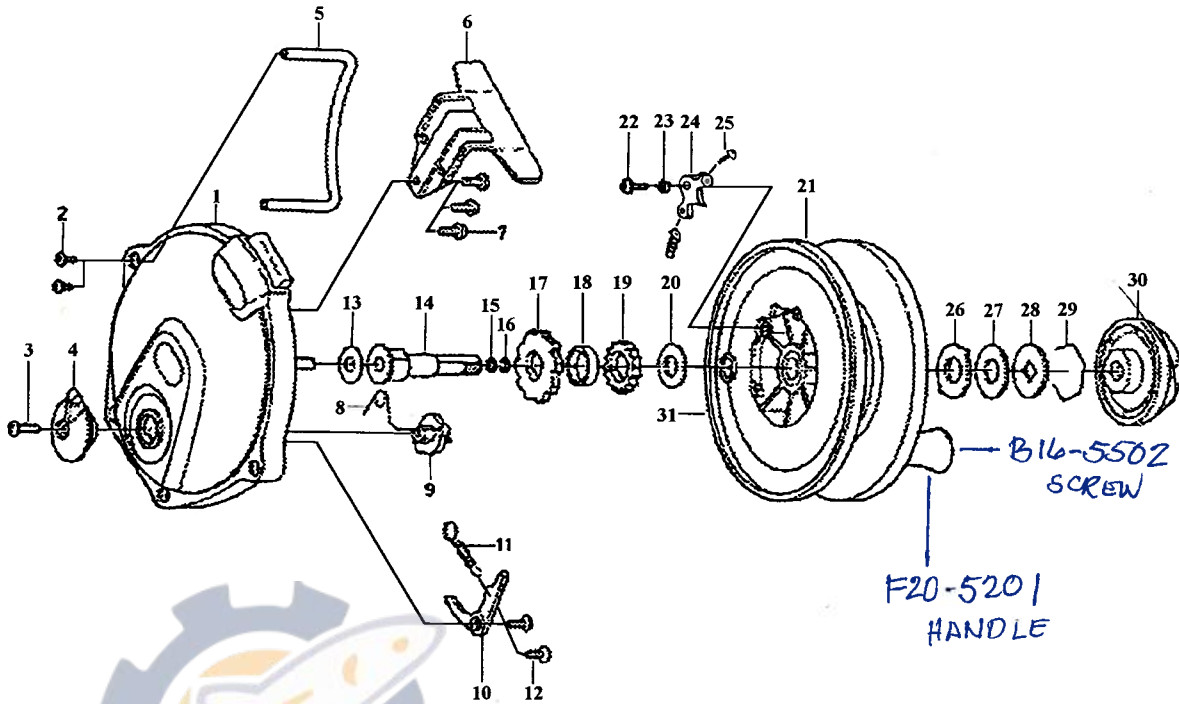

Key No.	Parts No.	Parts Name
1	F19-2501	BODY
2	351-1803	LINE GUARD SCREW
3	E45-4001	DRAG LEVER SCREW
4	F18-9701	DRAG LEVER
5	B99-7901	LINE GUARD
6	F19-0302	STAND
7	B11-2802	STAND SCREW
8	F19-0601	DRAG CAM SPRING
9	F19-1401	DRAG CAM
10	F19-1501	STOPPER PLT
11	F19-1201	STOPPER PLT SPRING
12	352-9503	STOPPER PLT SCREW
13	F18-9901	DRIVE SHAFT SPRING
14	F18-9501	DRIVE SHAFT
15	B41-1701	DRIVE SHAFT WASHER
16	320-8202	DRIVE SHAFT RET

Key No.	Parts No.	Parts Name
17	F19-0801	RATCHET
18	F19-0001	SPACING SLEEVE
19	F19-0701	CLICK GEAR
20	F19-0101	SPOOL WASHER
21	F19-2601	SPOOL
22	E33-0402	CLICK PAWL SCREW
23	F19-1101	CLICK PAWL COLLAR
24	F19-0901	CLICK PAWL
25	F19-1301	CLICK SPRING
26	372-3832	EARED WASHER
27	B36-0204	DRAG WASHER
28	B36-0303	KEY WASHER
29	F02-3901	DRAG WASHER RET
30	F19-2801	DRAG KNOB
31	F22-1701	O RING